

Earthing switch FHE-B3

Earthing switch for 15 kV and 25 kV AC-overhead lines

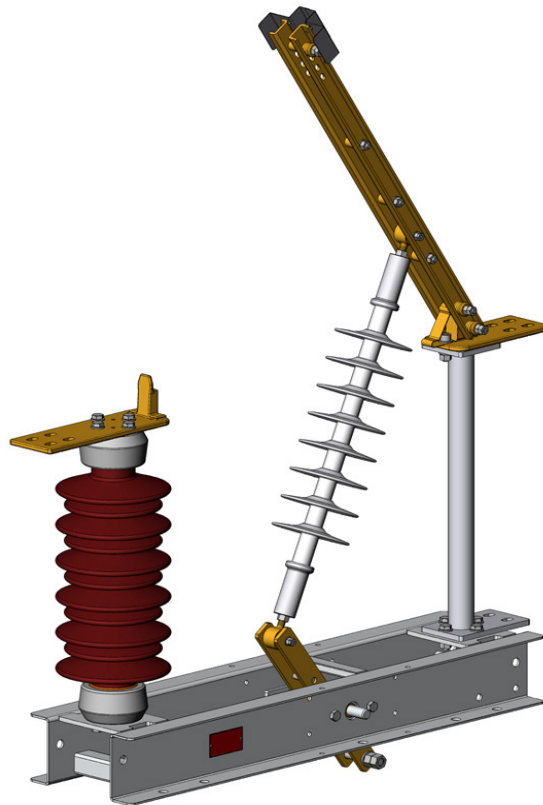

The earthing switch FHE-B3 can be used in an AC-overhead line (OHL) up to 25 kV to earth already isolated sections of conductor line.

The earthing switch FHE-B3 is of knife type with one fixed insulator and one aluminium bolt. This ensures a safe and solid earthing point and is able to carry short circuit currents. A silicone rod insulator takes over the switching procedure.

The flat terminals, supported by the insulator and aluminium bolt, allow different connection variations.

The earthing switch is designed to be operated by rod with linear movement (motorised or manual).

Our switches are manufactured according to IEC 60694 and 62271-102. Thanks to a very long experience in the branch, our company has been awarded with accreditations by different national railways.

Features and benefits

- Compact design
- All steel parts either in stainless steel or hot-dip galvanised
- Solid and stable base frame
- Insulator available in porcelain or alternatively in silicone
- Excellent earth connection thanks to the bolt and earth-terminal in aluminium
- Fixing on the supporting structure either by clamping (free setting) or screwing (holes in the base frame)
- Easy on-site installation and setting
- High reliability: up to 10'000 cycles
- All copper conducting parts either silver, nickel or tin-plated
- Practically maintenance-free
- As option: direct status indication is available (voltage-free contacts); retrofitting also possible

Technical data

Rated values

Nominal voltage U_{nom}	kV AC	25	15
Rated voltage U_r	kV	27.5	17.5
Highest system voltage U_{lim1}	kV	52	36
Rated frequency f_r	Hz	16.7-60	16.7 - 60
Rated normal current I_r	A	-	-
Rated short time withstand current I_k	kA	40	40
Peak withstand current I_p	kA	100	100
Duration of short circuit t_k	s	1	1

Withstand values

One minute power frequency withstand voltage (50 Hz, dry/wet) U_d - across the isolating distance	kV	95	70
Impulse withstand voltage (1.2/50 μ s) U_p - across the isolating distance	kV	250	170

Insulators

Material		porcelain or silicone	
Highest system voltage U_{lim3}	kV	52	36
Minimum creepage distance	mm	1'300	715
Minimum bending breaking load	kN	4	4

Construction characteristics

Mechanical life	cycles	10'000	10'000
Operating stroke	mm	180	120
Approximate weight (with porcelain insulators)	kg	64	49
Approximate weight (with silicone insulators)	kg	52	42

Dimensional drawings

FHE-B3-25

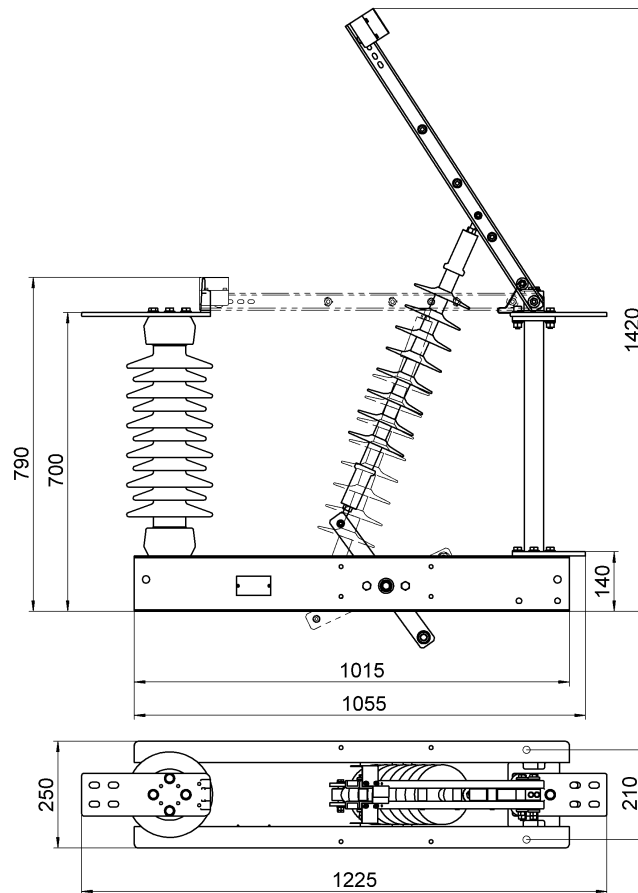

FHE-B3-15

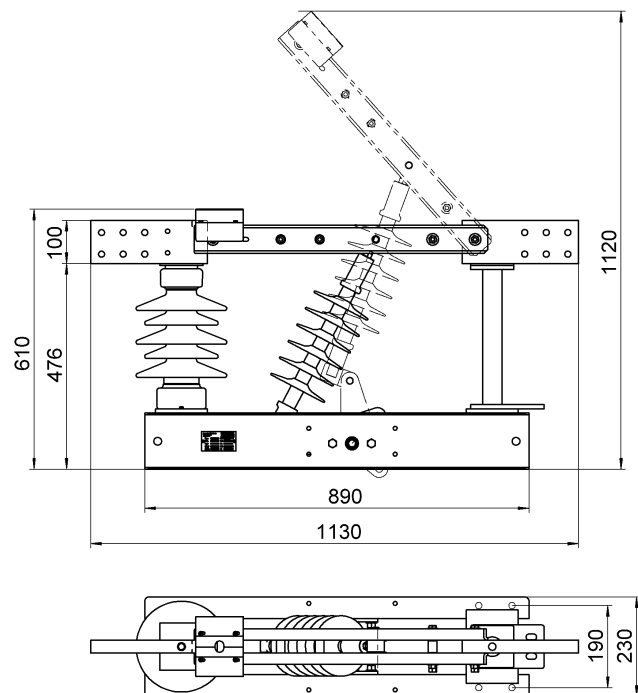

Ordering information

Basic types	Description	Article-No.
FHE-B3-25	Earthing switch 25 kV with porcelain insulators	17103
FHE-B3-15	Earthing switch 15 kV with porcelain insulators	on request

Options:

S = silicone insulators instead of porcelain

I = with status indication (1x open, 1x closed)