

Isolating switch FHF-B2

Isolating switch for 15 kV and 25 kV AC-overhead lines

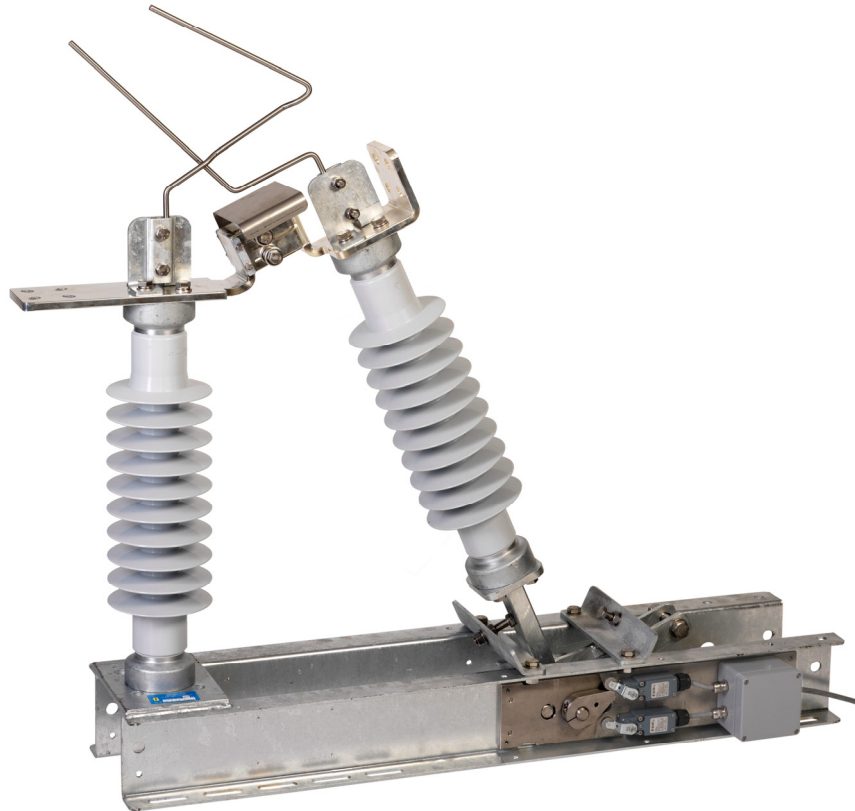

The isolating switch - also named disconnecter or isolator - FHF-B2 can be used in an AC-overhead line (OHL) up to 25 kV to switch on or to isolate sections of conductor line.

Usually actuated at a no-load state, it is able to switch capacitive or inductive small currents up to 6 Amperes.

The disconnecter FHF-B2 is of rocker type with one fixed and one movable insulator.

The flat terminals, which are fastened onto the insulators,

allow different connection variations.

The isolating switch is designed to be operated by rod with linear movement (motorised or manual).

Our switches are manufactured according to IEC 60694 and 62271-102. Thanks to a very long experience in the branch, our company has been awarded with accreditations by different national railways.

Features and benefits

- Very compact design
- All steel parts either in stainless steel or hot-dip galvanised
- Solid and stable base frame
- Main contact with icing protection
- Insulators available in porcelain or alternatively in silicone
- Fixing on the supporting structure either by clamping (free setting) or screwing (holes in the base frame)
- Easy on-site installation and setting
- High reliability: up to 10'000 cycles
- All conducting parts either silver, nickel or tin-plated
- Practically maintenance-free
- As option: direct status indication is available (voltage-free contacts); retrofitting also possible
- As option: can be equipped with an earthing heel whose function is to ensure an earthing as soon as the disconnecter is open

Technical data

Rated values

Nominal voltage U_{nom}	kV AC	25	15
Rated voltage U_r	kV	27.5	17.5
Highest system voltage U_{lim1}	kV	52	36
Rated frequency f_r	Hz	16.7-60	16.7 - 60
Rated normal current I_r	A	2'000	2'000
Rated short time withstand current I_k	kA	31.5	25
Peak withstand current I_p	kA	80	62
Duration of short circuit t_k	s	3	3

Withstand values

One minute power frequency withstand voltage (50 Hz, dry/wet) U_d			
- between earth and pole	kV	95	70
- across the isolating distance	kV	110	80
Impulse withstand voltage (1.2/50 μ s) U_p			
- between earth and pole	kV	250	170
- across the isolating distance	kV	290	195

Making and breaking current

Breaking current at power factor 0.1 (inductive/capacitive) I_{break1}	A	2	2
Making current at power factor 0.1 (inductive/capacitive) I_{make}	A	2	2
Breaking current at power factor 0.35 (inductive/capacitive) I_{break2}	A	6	6

Insulators

Material		porcelain or silicone	
Highest system voltage U_{lim3}	kV	52	36
Minimum creepage distance	mm	1'300	715
Minimum bending breaking load	kN	4	4

Construction characteristics

Mechanical life	cycles	10'000	10'000
Operating stroke	mm	180	200
Approximate weight (with porcelain insulators)	kg	83	45
Approximate weight (with silicone insulators)	kg	58	30

Dimensional drawings

FHF-B2-25

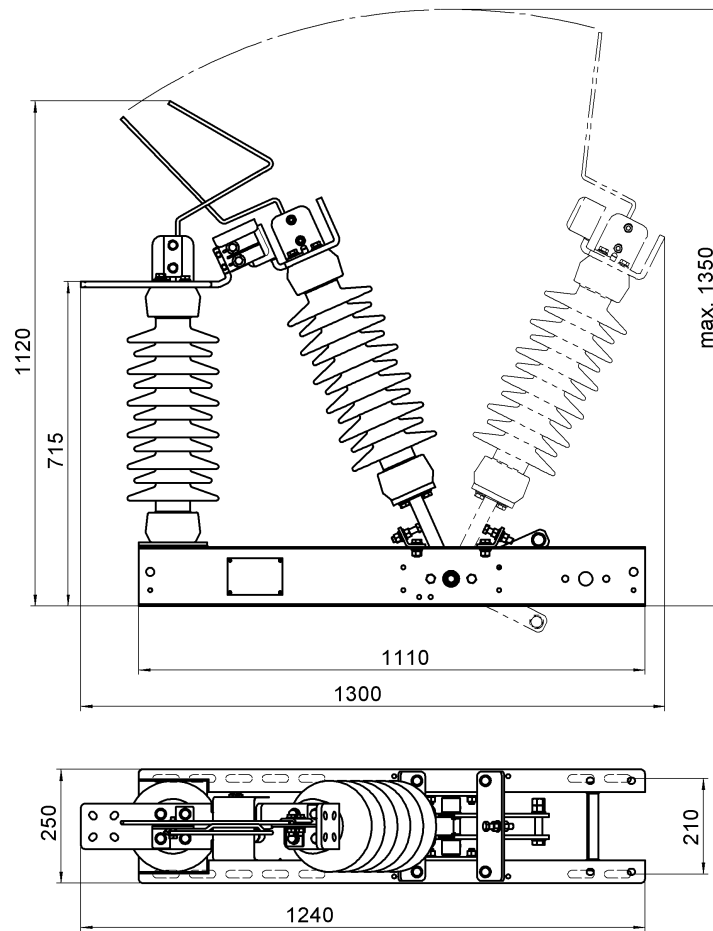

FHF-B2-15

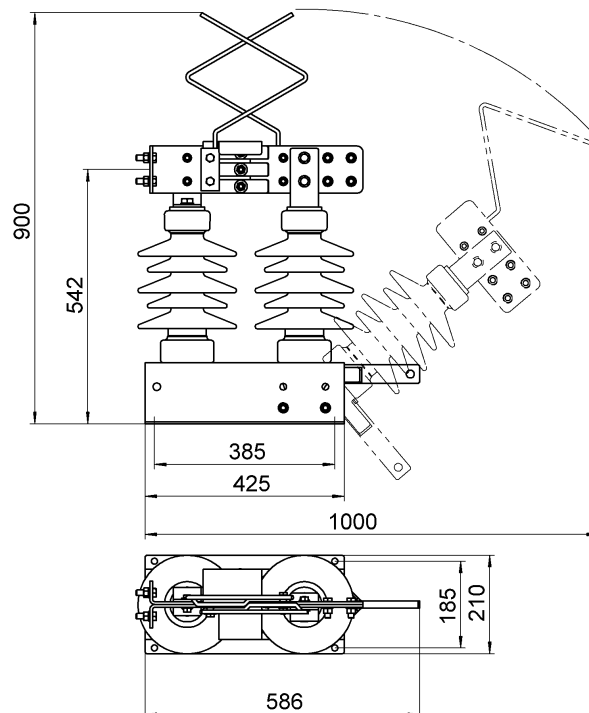

Ordering information

Basic types	Description	Article-No.
FHF-B2-25	Isolating switch 25 kV with porcelain insulators	17921
FHF-B2-15	Isolating switch 15 kV with porcelain insulators	14724

Options:

- S = silicone insulators instead of porcelain
- I = with status indication (1x open, 1x closed)
- E = earthing heel