

Overhead line switchgear



# Overhead line switchgear

## General

Rauscher & Stoecklin AG offers a full range of switchgear for overhead line equipment for electric traction systems at AC voltages of 15 kV and 25 kV.

Thanks to our long experience in the branch, we have been awarded with accreditation by different national railways.

Depending on the requirement, we can deliver complete systems or just the component you need e.g.: disconnecter, load break switch, earthing switch, motor drive or manual handle, rod linkage.

In addition to the conventional products, we are able to deliver two-pole switches (installed as parallel or antiparallel) as well as special designs for use in tunnels or in substations. Operating rods can even be replaced by flexible actuating systems in case of space-restricted areas.

## Typical installation

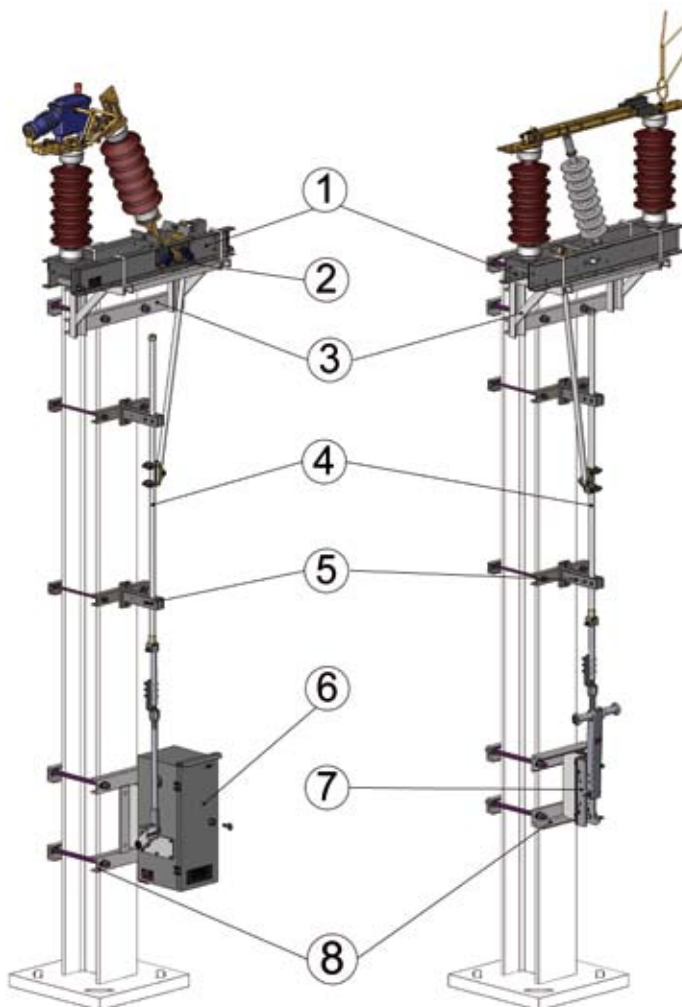

- |                                     |                        |
|-------------------------------------|------------------------|
| 1 (Switch-) Disconnecter            | 5 Rod guide            |
| 2 Direct status indication (option) | 6 Motor-drive          |
| 3 Supporting structure              | 7 Manual handle        |
| 4 Rod linkage                       | 8 Supporting structure |

## Switches

### Design

All our disconnectors comply with the international standards in particular with IEC 60694, 62271-102 and 60265-1.

To ensure a long-life service (up to 10'000 cycles), all the steel parts are either hot-dip galvanised or made of stainless steel. In addition, all conducting parts are either silver-, nickel- or tin-plated.

Thanks to these features, our switches are practically maintenance-free.

Our switches are available in three different designs: two rocker-type models with one (design B2) or two (design B1) fixed HV-terminals. One knife-type model (design B3) with two fixed terminals completes our standard product range.

### Options

Although the above described models cover the most customers' requirements, a range of options is also available: direct status indication, silicone insulators, forced earthing, two-pole-switch kit.

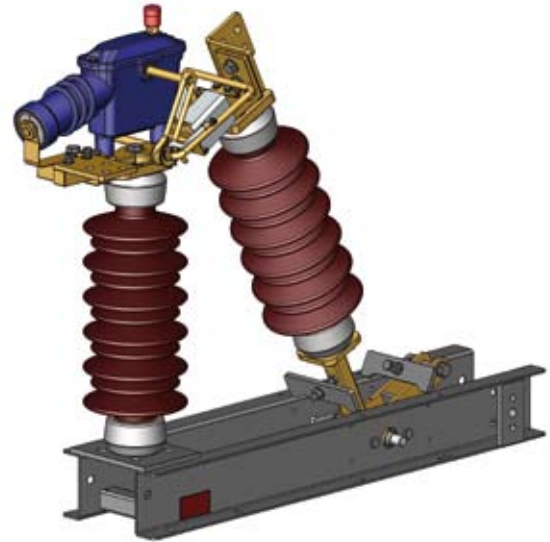

### Function

Basically, the switch family produced by Rauscher & Stoecklin AG can be divided in three sub-groups: Load break switches, isolating switches and earthing switches.

→ A load break switch (switch-disconnector) is able to connect or isolate sections of conductor line under load up to 2000 A.

Thanks to the use of a high-vacuum disconnecting chamber, no external arc occurs during the switch-off procedure. This is particularly interesting for installations in space-restricted areas such as tunnels.

→ An isolating switch (disconnecter, isolator) is usually actuated at a no-load state. It is able to switch small current up to 6 Amperes and is fitted with arcing horns whose function is to protect the main contact during the switching sequence.

→ In addition the three basic designs, a new one (design B4) has been developed to allow one disconnector to energise two different overhead lines alternatively.

→ An earthing switch is used to earth an already isolated section of conductor line. It is able to carry short-circuit currents.

A special design (B4) had been developed to allow one disconnector to either energise or isolate or earth a section of conductor line.

The switch-off procedure of the load break switch consists of four steps

❖ 1

The switch is closed; **the line is energised**. The current flows from side A to side B via the main contact. The vacuum disconnecting chamber circuit (parallel to the main contact) carries only a small part of the operating current (<1%).

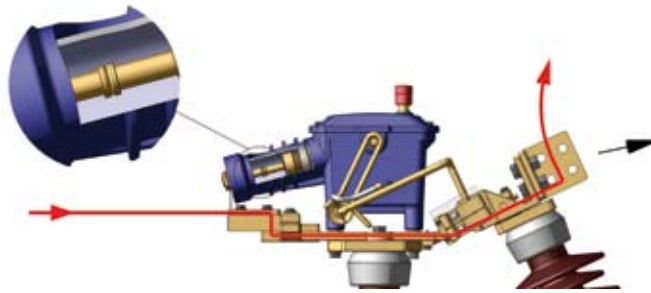

❖ 2

The two parts of the main contact are separated. At this moment the current flows entirely through the vacuum disconnecting chamber circuit.

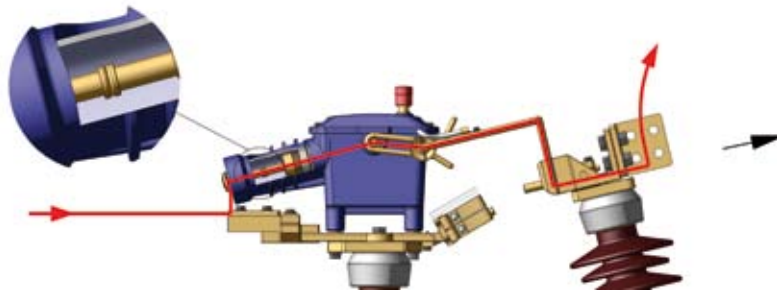

❖ 3

As soon as the isolating distance between the two parts of the main contact is sufficient, the vacuum disconnecting chamber opens the vacuum tube contacts. Now, no current flows through the switch. The line is no longer energised.



❖ 4

The switch-disconnector has reached its open position; **the line is now isolated**.



**Product overview**

Function	Design	OHL-voltage	
		15 kVg	25 kV
Load break switch	B1 B2 B3	FHV-B1-15 FHV-B2-15 FHV-B3-15	FHV-B1-25 FHV-B2-25 FHV-B3-25
Isolating switch	B1 B2 B3 B4	FHF-B1-15 FHF-B2-15 FHF-B3-15	FHF-B1-25 FHF-B2-25 FHF-B3-25 FHF-B4-25
Earthing switch	B3 B4	FHE-B3-15	FHE-B3-25 FHE-B4-25

*Design overview*



B1



B2



B3



B4

### Operating rods

The switch can be operated either by a manual handle or by a motor drive.

The movement transmission is usually realised through a rod linkage system which is simple and cost-effective, or alternatively, for space-restricted areas, through a flexible actuating system like Flexball®.

### Motor-drive

Our motor drive MFL 200 benefits from our long experience. It is of modular design and the electrical part can easily be adapted to fulfil specific customer's requirements.

The outside cubicle, made of stainless steel, is designed for the worst weather conditions and is completely maintenance-free.



### Manual handle

For situations where the motorised design is either not possible or, for security reasons, not desired, a robust 2-position manual handle is available. It can be connected to the same operating rods as for the motorised version. In addition to that, it is possible to deliver it with a mechanical interlocking system to avoid wrong manoeuvres during the switching sequence.

← Manual handle

Motor-drive →

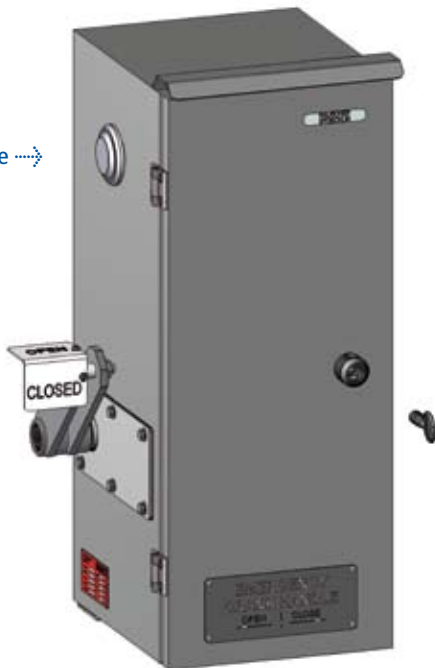

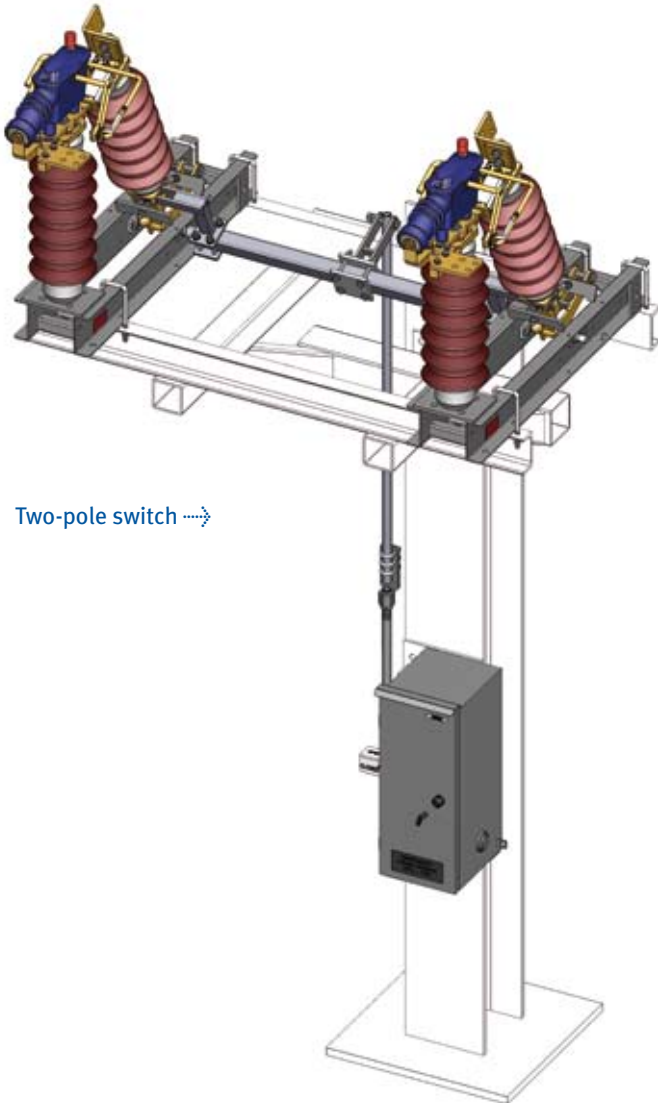

Two-pole switch →

### Two-pole switch

In case of power supply through an auto-transformer system, it could be useful to install a two-pole switch on the mast. With an additional set, two single-pole switches can be combined to give one two-pole switch using only one actuating system. As such switches are mainly motorised, the economy could be very substantial.

### Special installations

The use of a Flexball® transmission system allows optimal movement transmission between the motor drive and the switch in difficult situations as, for instance, tunnels.

Special installation for tunnel →



**Rauscher & Stoecklin AG**

Reuslistrasse 32, CH-4450 Sissach  
T +41 61 976 34 66, F +41 61 976 34 22  
info@raustoc.ch, www.raustoc.ch